



September 26, 2006

Executive Summary

Dangerous Voltages and Currents Present on Wind Power Turbine Generators – Must be Discharged to Ground for Reliable Operation

The wind turbine generator industry continues to be the fastest growing clean energy source where reliability is key to profitable operation. Bearings and other critical components frequently fail because of high shaft currents generated in the wind turbine nacelle. Reliable maintenance-free protection from rotor shaft high voltages and currents will reduce maintenance costs and improve up-time for wind turbine owners and operators.

Problem: Wind turbine generator stator windings and rotors are directly connected to the power grid. Unlike the stator, the rotor is connected to the same grid via a converter. The converter makes operation possible at variable rotor speeds while maintaining constant stator voltage and frequency outputs to the grid. This system introduces dangerous rotor shaft voltages, and due to the high frequency converter switching, the generators, gear boxes, and other critical components are exposed to dangerous high frequency shaft currents causing EDM (Electrical Discharge Machining).

Solution: A new shaft grounding technology known as AEGIS WTG (Wind Turbine Shaft Grounding System) uses circumferential rings of conductive micro fibers to discharge these harmful currents to ground. The AEGIS WTG shaft grounding system was successfully tested and applied to a GE 1.5 MW generator.

Up-tower voltages of 1200 volts peak were measured on the shaft of the turbine. After AEGIS WTG was installed, the voltage was reduced to 32 volts peak. Concurrently, 56 amps of high frequency shaft currents are being diverted through the AEGIS WTG shaft grounding ring.

The AEGIS WTG, a grounded conductor ring, is placed between the stator winding and the rotor. Dangerous rotor shaft voltages are diverted to ground, protecting bearings and other vulnerable components.

Electro Static Technology-ITW
31 Winterbrook Road
Mechanic Falls, ME 04256
Toll free 1-866-738-1857
Fax 1-207-998-5143
www.est-aegis.com

Test Report of Wind Turbine Shaft Voltage and Current Readings

Location: Wind Generation Facility, Texas USA

Wind Turbine Equipment:

Wind Turbine Generator: 1.5 MW

Manufacturer: GE

Conditions:

Outside Temp 86 F Sunny

Winds 5-10 knots

NeCelle Ambient Temp: 98 F

Generator Grounding Ring Shaft Diameter DE: 6.181" [157.0mm]

System support grounding during test: None

Objective: Confirm AEGIS WTG™ shaft grounding ring functionality with real time documented data.



AEGIS WTG™ ring disassembled



AEGIS WTG™ ring Assembled

Installation:

1. **AEGIS WTG™ ring was installed up-tower on the generator shaft drive end. The WTG ring was insulated from the frame of the generator to obtain performance voltage & current readings. Mounting brackets were installed as temporary supports with insulation pads.**

AEGIS WTG™ Wind Turbine Grounding

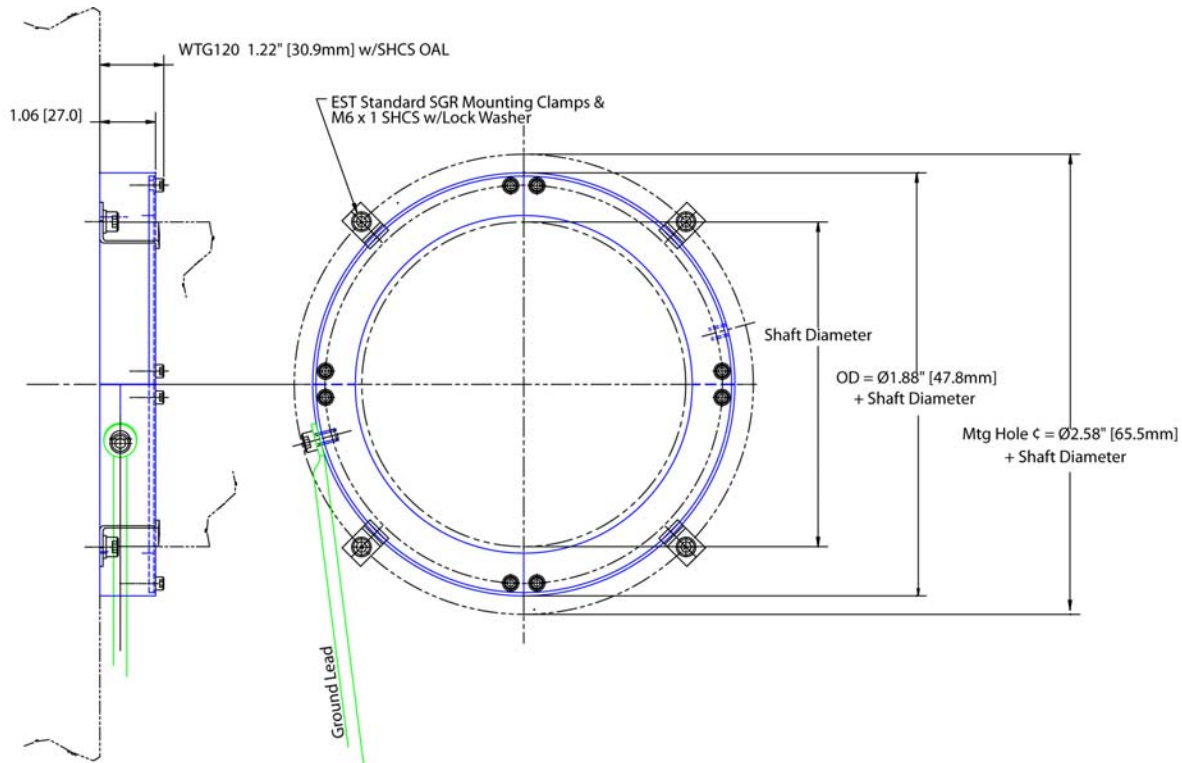

Drawing of AEGIS WTG™ with dimensions

2. Tektronix Model #TDS3014B Oscilloscope was used for voltage & current readings 100MHz, 1.25 GS/s with maximum voltage readings 600 volts. Current probe of 60 amps peak
3. A hand held Ohm meter was used to confirm the WTG ring was insulated from the generator earth ground.
4. A #4 Ground wire with a length of approximately 24" was attached to the WTG grounding ring and lead to the generator grounding strap. The grounding wire could be disconnected or contacting earth ground.
5. All original shaft earth grounding brush systems within the generator were temporarily removed.
6. Schematic diagram of test setup:

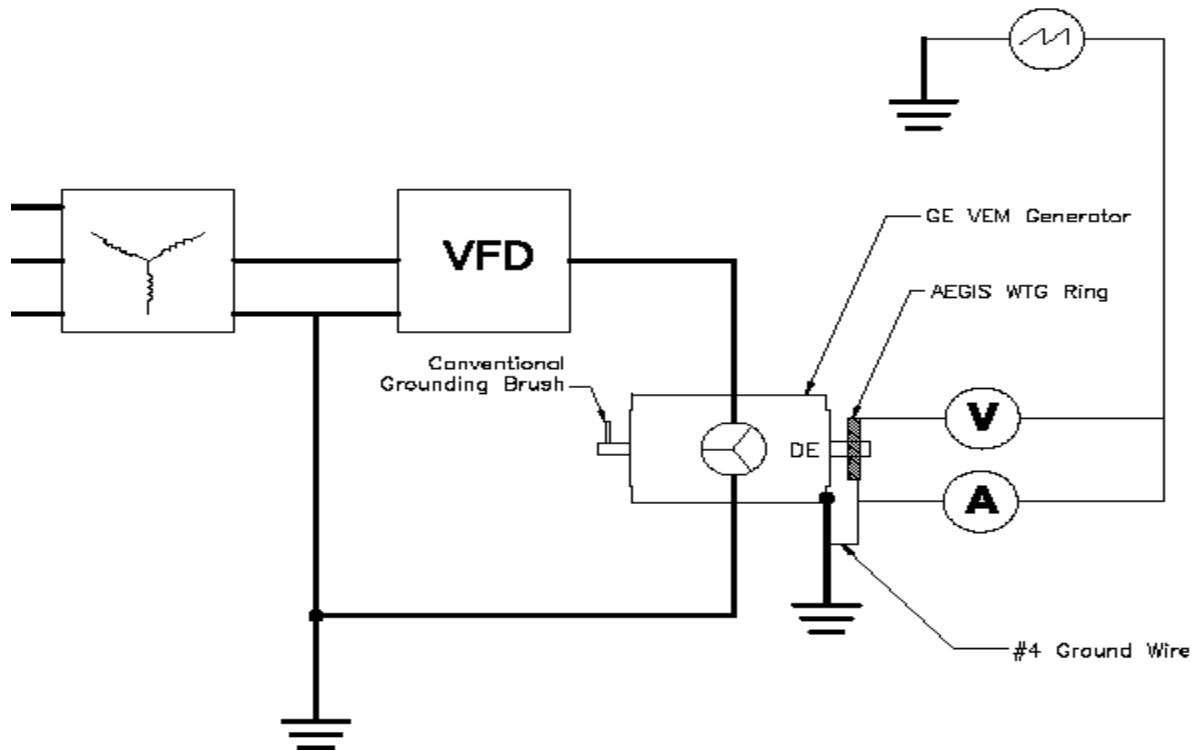

Schematic Diagram of Test

On Line Testing:

Test #1: Ungrounded generator shaft voltage test:

Determine the actual shaft voltage the generator acquires during on line operation with no generator shaft grounding.

1. The #4 grounding wire was removed from earth ground.
2. O-scope channel #1 probe was attached to the WTG
3. The wind turbine/generator was activated and accelerated to sync with the grid and go on line.
4. Run time on line (1) minute max.

Results

Shaft voltage before going on line: 5-10 volts Peak to Peak
Shaft voltage after go on line: 600+ volts Continuous

Initial Conclusion

- The O-Scope was clipping at 600 volts, voltages could be as high as 1200volts
- Due to dangerous shaft voltages the wind turbine/generator was shut down after approx. (1) minute on line.

Test #2: Determine the actual shaft voltage the generator acquires during on line operation with AEGIS WTG shaft grounding generator protection.

1. The #4 grounding wire from WTG was clamped to earth ground .
2. O-scope channel #1 probe was attached to the WTG
3. O-scope channel #3 current probe was clamped over the ground wire lead
4. The wind turbine/generator was activated and accelerated to sync with the grid and go on line.
5. Run time on line 5 minutes

Results

Shaft voltage before going on line: 3-4 volts Peak to Peak
Shaft voltage after go on line: 25-40 volts Peak to Peak

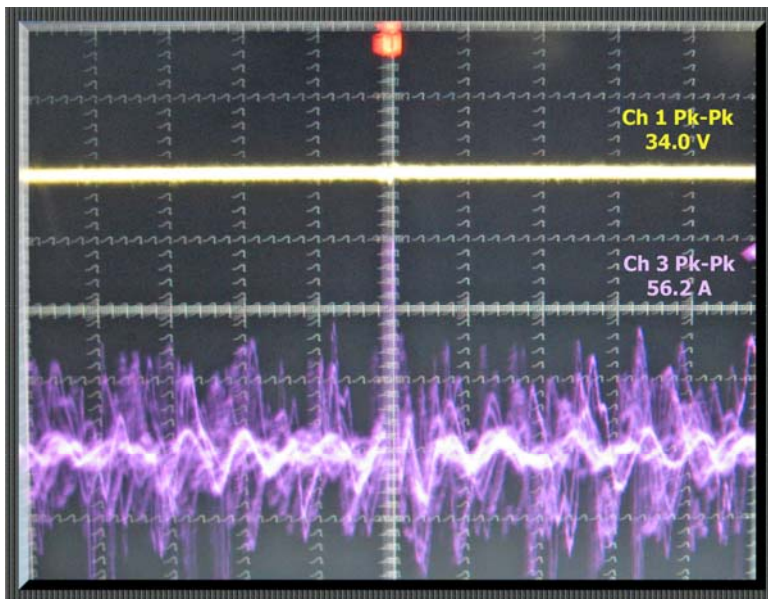

Test #2: Real time oscilloscope test readings with WTG generator shaft grounding ring results 38 volts @ 59 amps

Initial Conclusion

- **As the generator was syncing on line the voltage fluctuated 25-40 volts Peak to Peak**
 - **After the generator was on line the voltage stabilized at a constant 28-30 volts and current readings peaked at 60 amps**
 - **The WTG shaft grounding system performed as expected and stabilized the generator shaft voltage.**
 - **Current was effectively discharged through the WTG**
-
-

Test Conclusions:

1. **The generator unprotected shaft voltage measuring well above 600 volts was reduced to a constant 30-40 volts peak to peak while simultaneously measuring a current flow of 50-60 amps when the WTG ring was implemented.**
2. **The remaining 30-40 volts is possibly due to the impedance to earth ground. This will not change dramatically however the consistent current flow through the WTG will protect the bearings from damage.**
3. **The unprotect generator shaft produced much higher shaft voltages then originally expected. Over 600 volts peak to peak.**
4. **The frequency of this current measuring 50-125 kHz explains why bearings are being damaged after they have been sleeved with insulation. The bearing insulation will not prevent higher frequency current transfer due to it reacting as a capacitor.**
5. **Standard mechanical brush protection is not affective with these higher frequencies due to intermittent shaft contact with standard brushes. This intermittent unprotected grounding will allow shaft voltages to climb to dangerous levels and allow bearing damage.**
6. **The current standard mechanical brush has pitted the shaft due to arcing.**
7. **Future testing could be completed with higher capacity scope and current probe. However the WTG ring system has proven to be a reliable grounding system for the Wind Turbine Generators.**
8. **The AEGIS WTG ring does not rely sole on a mechanical contact to the generator shaft for grounding. The conductive microfibers consist of millions of current transfer points that contact the shaft with virtually no friction. This light contact allows for long term reliable performance.**