

# AEGIS™ SGR uKIT Installation for IEC Motors

Patented Technology



## AEGIS™ SGR uKit Includes:

- (1) AEGIS™ SGR Bearing Protection Ring
- (4) universal brackets - Style 1
- (4) universal brackets - Style 2 (reversible)
- (4) universal brackets - Style 3
- (4) universal brackets - Style 4 (reversible)
- (4) 5-40 x 3/8" flat head screws
- (4) M3 x 10mm socket head cap screws
- (4) M3 split lock washers
- (4) M3 flat washers
- 5/64" allen wrench
- 2.5mm allen wrench

## Tools required for installation:

- 2.5mm drill
- M3 tap
- Fine grit emery cloth/sand paper
- CS015 AEGIS™ Colloidal Silver Shaft Coating (recommended)
- Loctite® Thread Locker (optional)

## For easy AEGIS™ Conductive Epoxy mounting:

- EP2400 AEGIS™ Conductive Epoxy
- Dremel tool for removing paint on motor end bracket
- Heat gun to expedite curing time of conductive epoxy

## Universal Bracket Styles all included in the uKIT

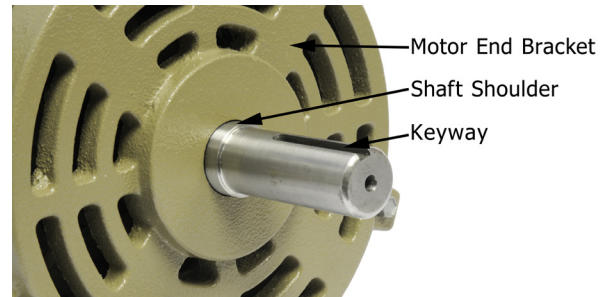
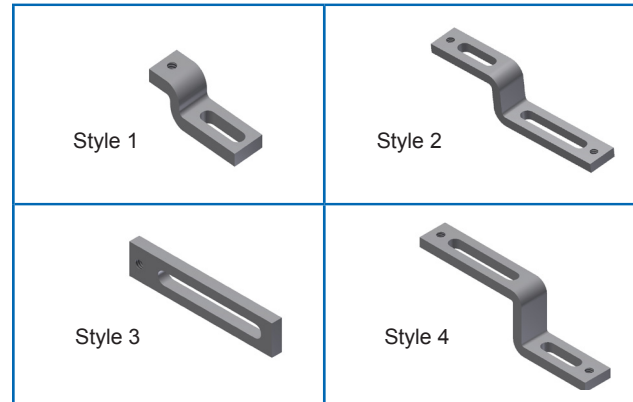

## Installation Guide:

- Choose either a 3 hole or 4 hole bracket pattern based on the configuration of the motor end bracket. Use a minimum of 3 brackets to safely secure the uKIT.

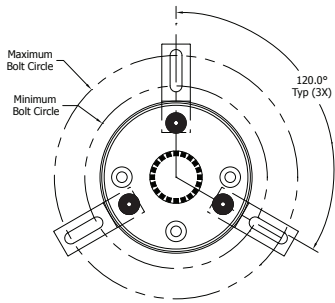

3 hole bracket pattern

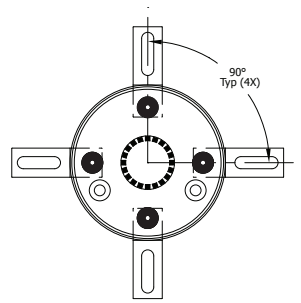

4 hole bracket pattern

- Select a bracket style based on the clearance needed on the motor end bracket/slinger/shaft shoulder. For specifications of each bracket, visit [www.est-aegis.com](http://www.est-aegis.com)
- Using the 5/64" allen wrench, assemble the brackets to the AEGIS™ ring using the 5-40 x 3/8" flat head screws. Loctite® can be used to secure the screws in this area only. Do not apply Loctite® to the entire screw because this is a path to ground.

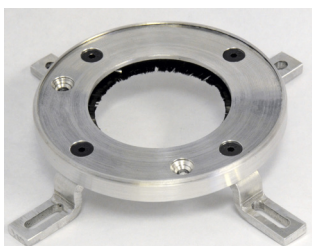

Apply Loctite to this area only

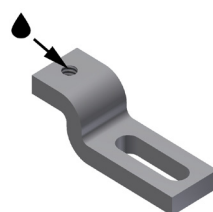

- Shaft preparation: Shaft must be clean & free of any coatings, paint, or other nonconductive material. Use emery cloth and then wipe with alcohol for best results.

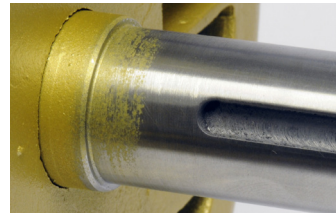

Wrong

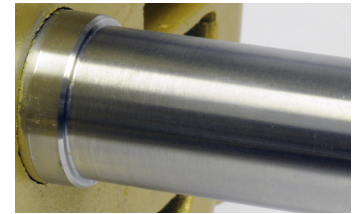

Right

- AEGIS™ SGR should not operate over a keyway. If SGR will operate over a keyway, fill keyway with a fast-curing epoxy putty (such as Devcon epoxy putty) in the area of contact. File epoxy smooth to shaft diameter.
- To increase the conductivity of the shaft we recommend applying a light coat of the AEGIS™ Colloidal Silver Shaft Coating PN CS015 to the area where the AEGIS™ microfibers are in contact with the motor shaft. Apply evenly all around the shaft. Use a heat gun for a faster drying process.

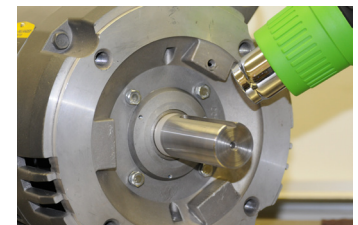

## **Drill and Tap Installation:**

1. Install the AEGIS™ SGR so that the aluminum ring maintains an even clearance around the shaft. Conductive MicroFibers™ must be in contact with the conductive metal surface of the shaft. Mark your bracket drill locations.

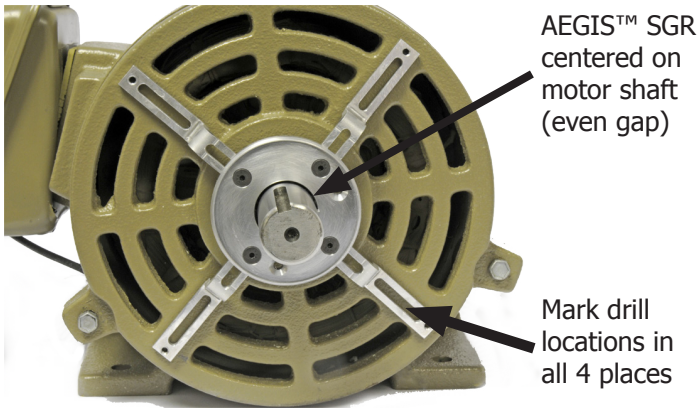

2. Prepare motor end bracket for installation with screws.
  - a. Drill (3 or 4) holes using a 2.5mm drill. Avoid drilling into bearing.
  - b. Depth of hole should be 6mm
  - c. Tap each hole with an M3 tap
  - d. Install the uKIT and secure to the motor using the M3 cap screws, split lock washers and flat washers provided. The bolts provide the path to ground. Do not use Loctite® or any other non-conductive material to secure the screws.
3. After installation, test for conductive path to ground using Ohm meter. One probe on metal frame of SGR and one probe on bare metal of motor frame. NOTE: Motor must be grounded to common earth ground according to applicable standards.

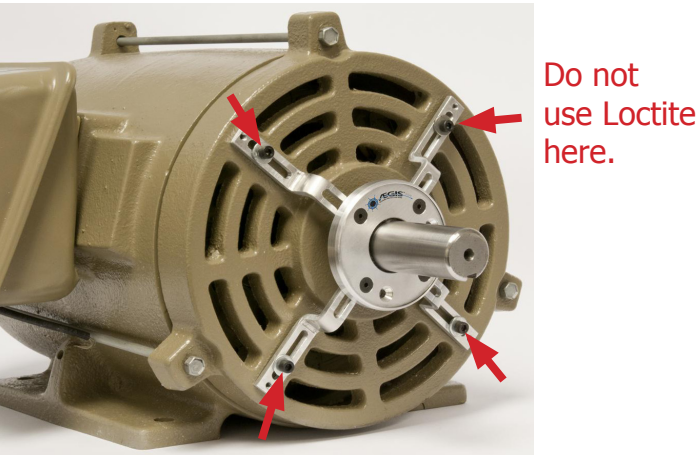

## **Conductive Epoxy Installation:**

1. AEGIS™ Conductive Epoxy EP2400 sold separately
2. Install the AEGIS™ SGR so that the aluminum ring maintains an even clearance around the shaft. Conductive MicroFibers™ must be in contact with the conductive metal surface of the shaft. Mark your epoxy locations.
3. Remove paint on the motor end bracket where the AEGIS™ uKIT brackets will be attached. These areas must be clean & free of any coatings, paint, or other nonconductive material.
4. Prepare conductive epoxy per package directions
5. Apply the epoxy to the universal brackets
6. Install the uKIT. Hold the uKIT in place until epoxy is firmly holding. Allow epoxy to cure for 4 hrs at or above 75°F. For quickest curing time, use a heat gun to heat epoxy for 10 minutes, then allow to cool.
7. After installation, test for conductive path to ground using Ohm meter. One probe on metal frame of SGR and one probe on bare metal of motor frame. NOTE: Motor must be grounded to common earth ground according to applicable standards.

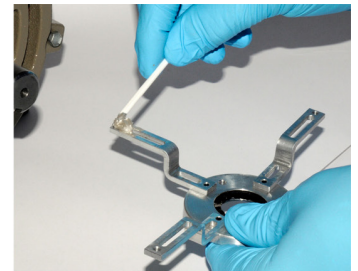
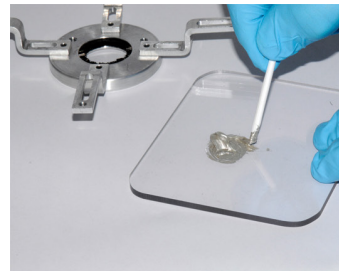
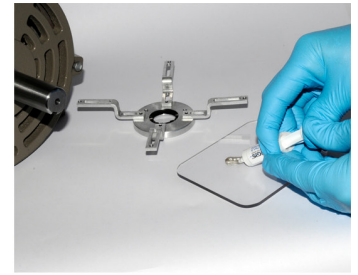
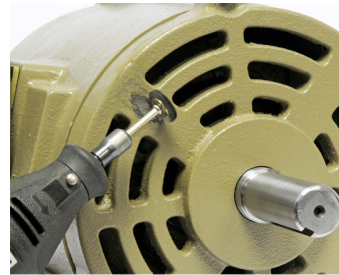

Manufactured by:



31 Winterbrook Road  
Mechanic Falls, ME 04256  
Toll Free: 866-738-1857  
Tel: 207-998-5140  
Fax: 207-998-5143

Sales/Customer Service: [sales@est-aegis.com](mailto:sales@est-aegis.com)  
Technical Support: [techsupport@est-aegis.com](mailto:techsupport@est-aegis.com)

[www.est-aegis.com](http://www.est-aegis.com)

**WARRANTY:** Units are guaranteed for one year from date of purchase against defective materials and workmanship. Replacement will be made except for defects caused by abnormal use or mishandling. All statements and technical information contained herein, or presented by the manufacturer or his representative are rendered in good faith. User must assume responsibility to determine suitability of the product for intended use. The manufacturer shall not be liable for any injury, loss or damage, direct or consequential arising out of the use, or attempt to use the product.

AEGIS™ SGR, AEGIS™ uKIT and Conductive MicroFiber™ are trademarks of Electro Static Technology-ITW  
Copyright © 2011 all rights reserved