

Fits Shaft Diameter: 1.875"
 NEMA FRAME
 284 T
 286 T
 324 TS
 326 TS
 364 TS
 365 TS

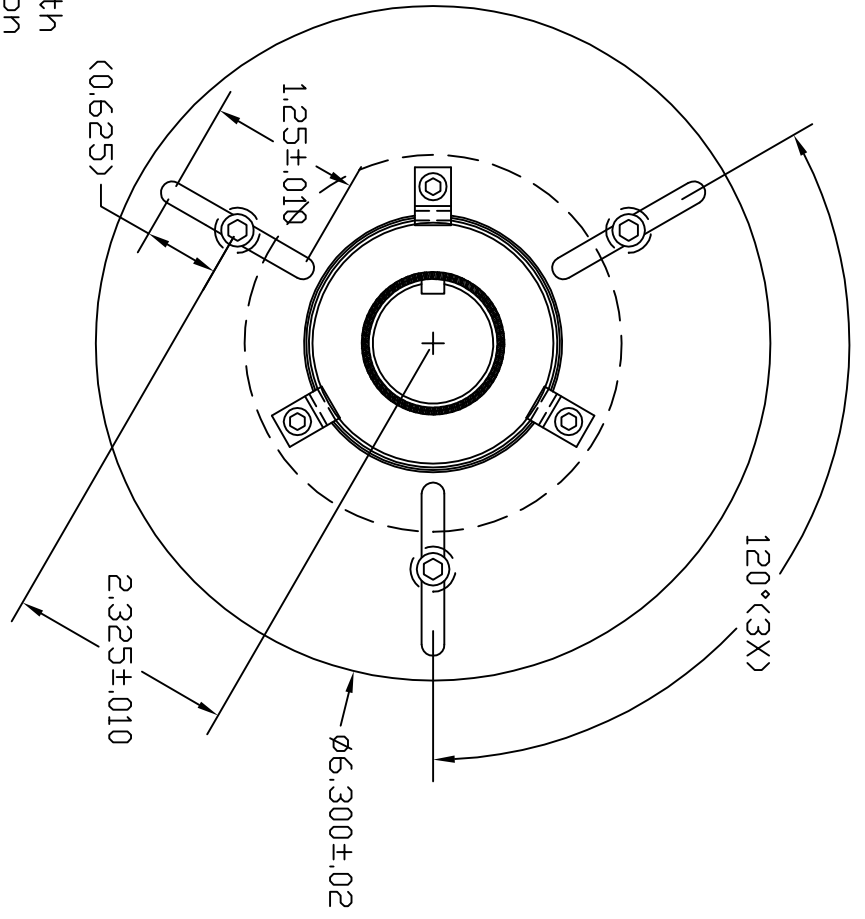

- Mounting Plate: Aluminum
- Flat Washers: #8 SAE Zinc-Plated Steel (rust resistant)
- Lock Washer: #8 medium Steel Split-plain steel
- Screws: 8-32 Socket Head Cap Screws-Alloy Steel
- Spacer: 3/8" DD #8 Screw Clearance -Aluminum
- Unthreaded Round Spacer

THEREIN ARE THE EXCLUSIVE PROPERTY OF ELECTRO STATIC TECHNOLOGY ISSUED IN STRICT CONFIDENCE AND SHALL NOT WITHOUT CONSENT, BE REPRODUCED, COPIED OR USED FOR ANY PURPOSE WHATSOEVER, EXCEPT BUSINESS WITH E.S.T.

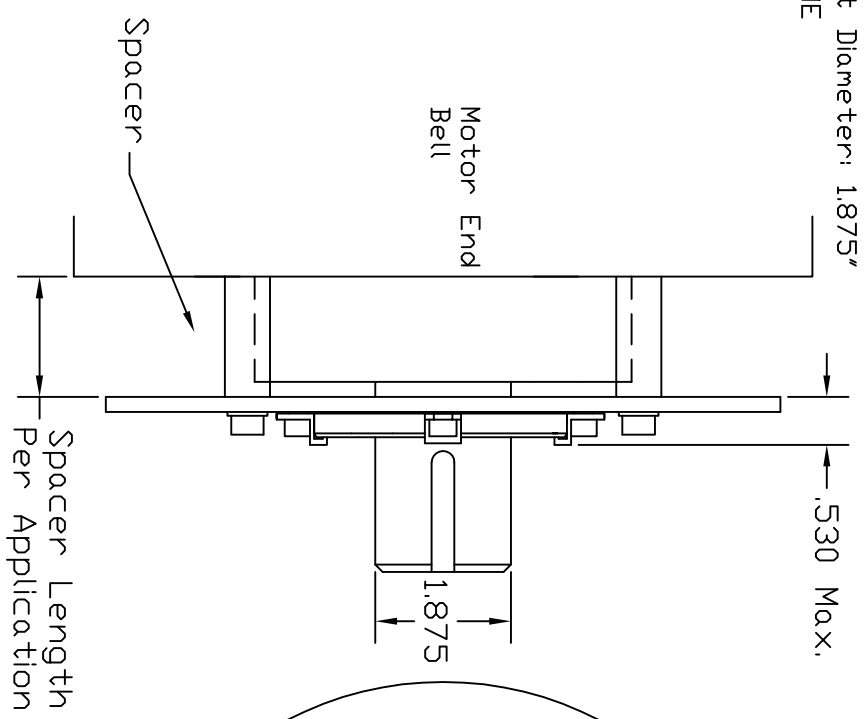

ELECTRO STATIC TECHNOLOGY
 AN ITW COMPANY

31 WINTERBROOK ROAD, MECHANIC FALLS, MAINE 04256
 PHONE (207)998-5140 FAX (207)998-5143

AEGIS NEMA SHAFT GROUNDING KIT

DATE: 4/18/07
 ENGINEER: J. Richardson

DWG NO. SGR-1.875-NEMA
 Rev. *B

US Patent No 7,136,271 & 7,193,836 Other patents pending