

Fits Shaft Diameter: 2.375"  
 NEMA FRAME  
 364 T  
 365 T  
 444 TS  
 445 TS  
 447 TS  
 449 TS

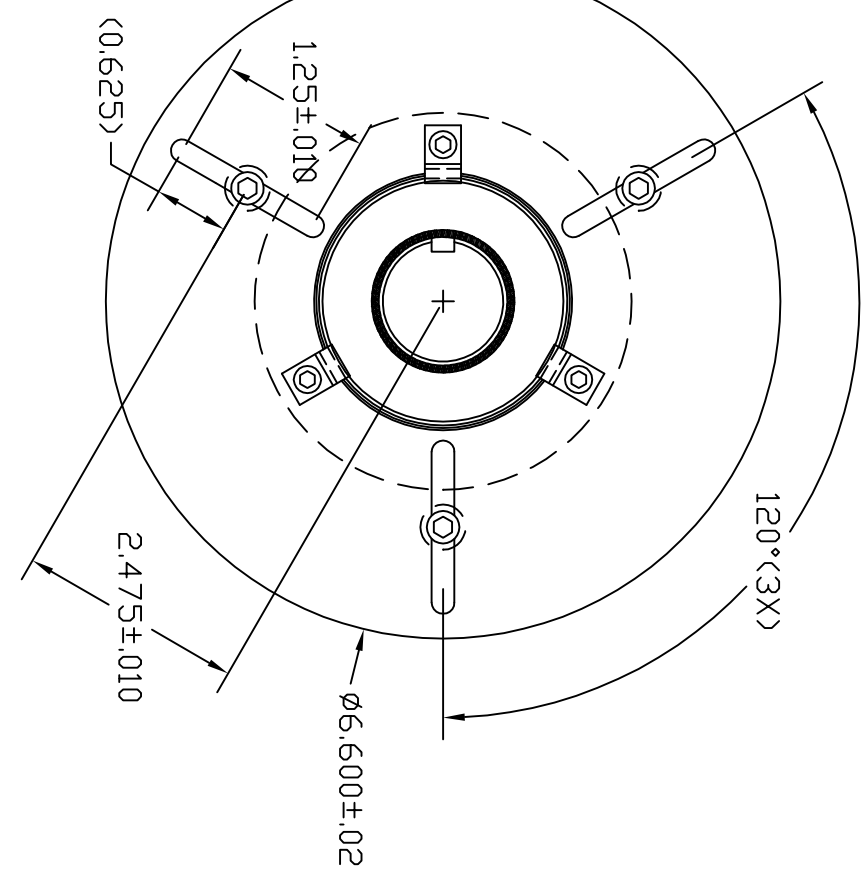

- Mounting Plate: Aluminum
- Flat Washers: #8 SAE Zinc-Plated Steel (rust resistant)
- Lock Washer: #8 medium Steel Split-plain steel
- Screws: 8-32 Socket Head Cap Screws-Alloy Steel
- Spacer: 3/8" DD #8 Screw Clearance -Aluminum
- Unthreaded Round Spacer

THEREIN ARE THE EXCLUSIVE PROPERTY OF ELECTRO STATIC TECHNOLOGY ISSUED IN STRICT CONFIDENCE AND SHALL NOT WITHOUT CONSENT, BE REPRODUCED, COPIED OR USED FOR ANY PURPOSE WHATSOEVER, EXCEPT BUSINESS WITH E.S.T.

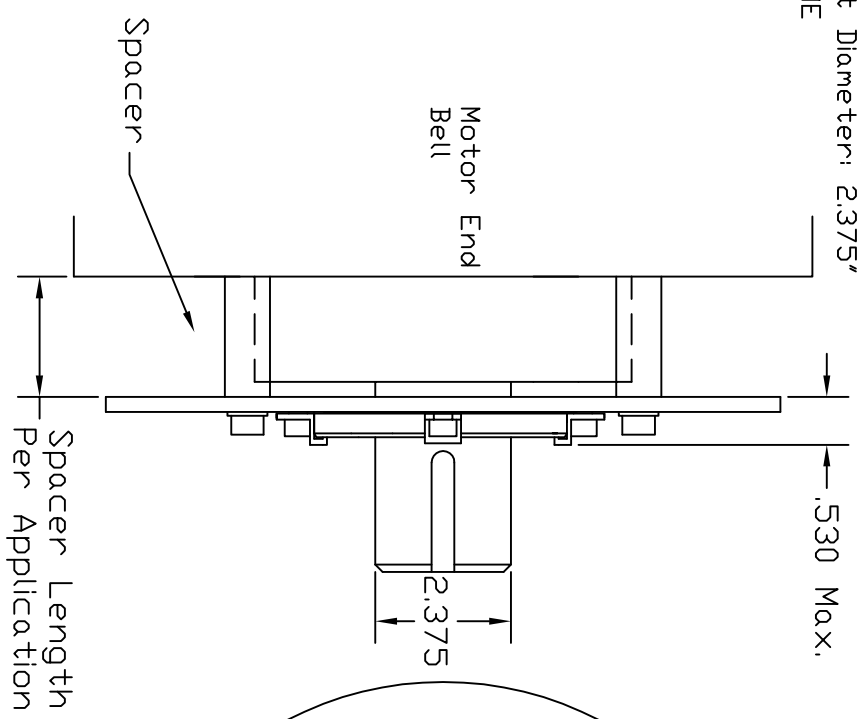

**ELECTRO STATIC TECHNOLOGY**  
 AN ITW COMPANY

31 WINTERBROOK ROAD, MECHANIC FALLS, MAINE 04256  
 PHONE (207)998-5140 FAX (207)998-5143

AEGIS NEMA SHAFT GROUNDING KIT

UNLESS OTHERWISE SPECIFIED  
 DIMENSIONS ARE IN  
 MILLIMETERS   
 INCHES

DATE: 4/18/07  
 ENGINEER: J. Richardson  
 DWG NO. SGR-2.375-NEMA  
 Rev. \*B

us Patent No 7,136,271 & 7,193,836 Other patents pending