

Patented Technology
www.est-aegis.com

Bolt Circle for NEMA motors

Shaft	Universal Bracket	
	MIN	MAX
0.625"	4.575"	5.375"
0.875"	4.825"	5.625"
1.125"	5.075"	5.875"
1.375"	5.325"	6.125"
1.625"	5.575"	6.375"
1.875"	5.825"	6.625"
2.125"	6.075"	6.875"
2.375"	6.325"	7.125"
2.875"	6.825"	7.625"
3.375"	7.325"	8.125"
3.625"	7.575"	8.375"
3.875"	7.825"	8.625"
4.375"	8.325"	9.125"
4.875"	8.825"	9.625"

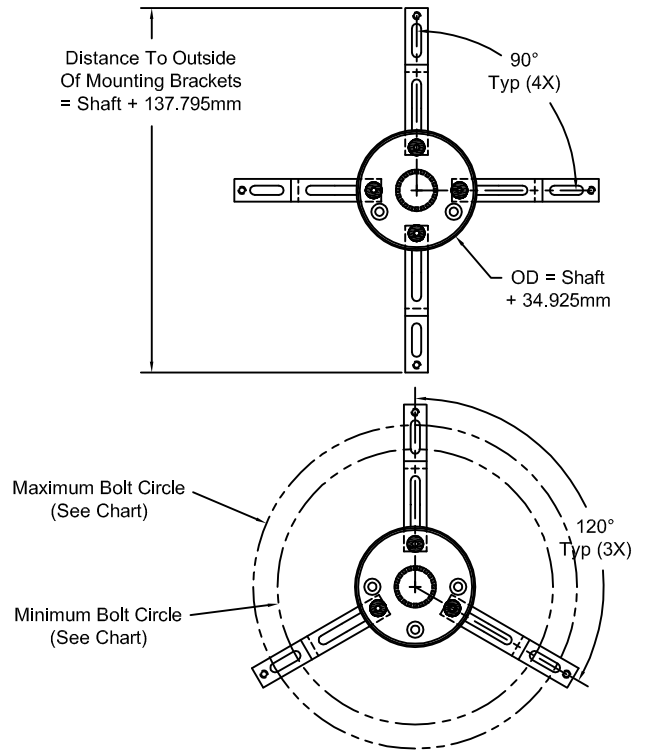
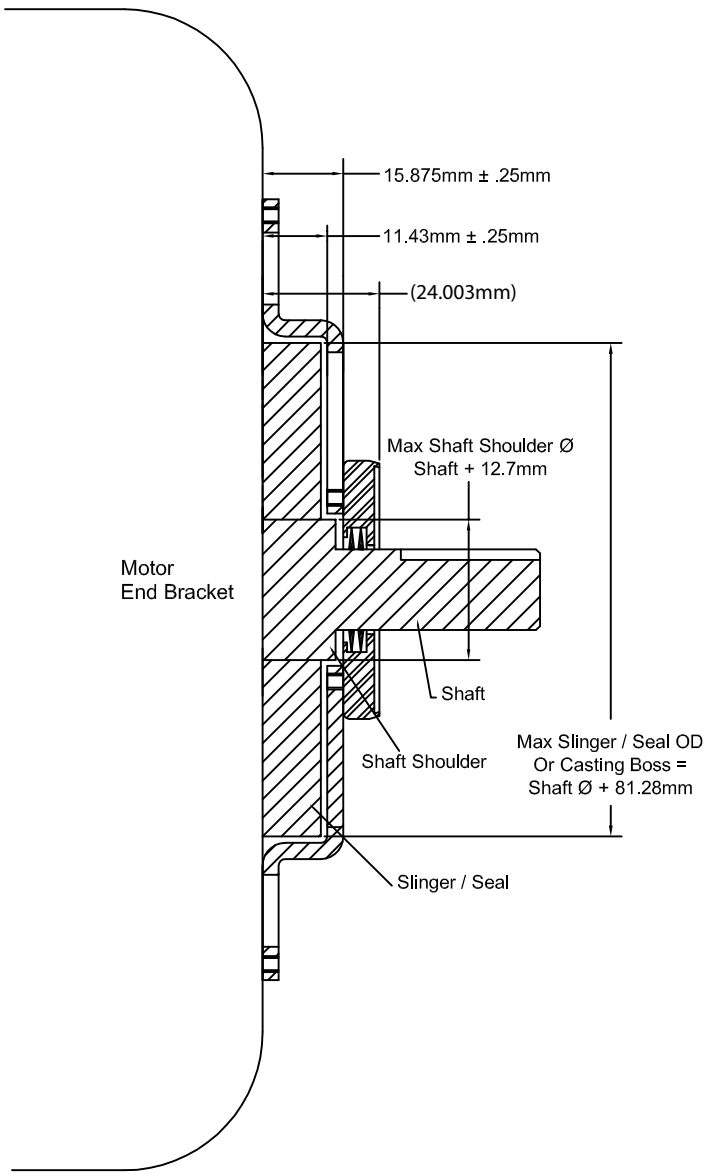

Bolt Circle for IEC motors

Shaft	Universal Bracket	
	MIN	MAX
28	128.33mm	148.65mm
38	138.33mm	158.65mm
42	142.33mm	162.65mm
48	148.33mm	168.65mm
55	155.33mm	175.65mm
60	160.33mm	180.65mm
65	165.33mm	185.65mm
70	170.33mm	190.65mm
75	175.33mm	195.65mm
80	180.33mm	200.65mm
95	195.33mm	215.65mm



Patented Technology
www.est-aegis.com