



AEGIS™ iPRO Bearing Protection Ring High Current Applications

- **Medium Voltage Motors**
- **Large Motors over 500HP**
- **Power Generators and Turbines over 750kW**



PROBLEM:

High Shaft Currents Damage Large Motors and Generators

High frequency shaft voltages and currents can cause motor and generator failures resulting in hundreds of thousands of dollars in system failure, maintenance and downtime. The use of variable frequency drives (VFD) with large AC motors induce high electrical voltages on the motor shaft. Once they exceed the resistance of the bearing lubricant, these voltages discharge to ground (typically the equipment housing), causing fusion craters and fluting in the bearings and motor failure.

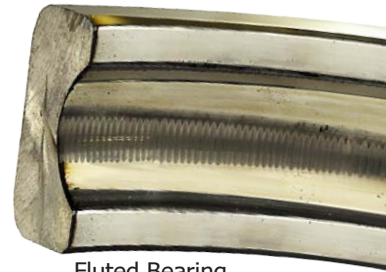

Fluted Bearing

SOLUTION:

AEGIS™ iPRO - Bearing Protection Ring

The new AEGIS™ iPRO Conductive MicroFiber Bearing Protection Ring reduces maintenance and helps prevent catastrophic failure by safely channeling harmful shaft currents to ground. Using proprietary Electron Transport Technology, the conductive microfibers inside the AEGIS™ iPRO provide the path of least resistance for damaging bearing currents, preventing electrical damage to motor bearings and dramatically extending motor and generator life.



"... AEGIS™ rings were very high quality and split ring alignments were perfect. This made installation easy."

*Thomas L. Gatesman
Electrical Project Engineer
Arcelor Mittal*





**AEGIS™ iPRO
HIGH CURRENT
BEARING PROTECTION RING**



Available in Solid Ring or Split Ring design

Screws and washers for bolt through mounting included. Custom designed mounting brackets may be required depending on equipment.

INCLUDED!

EACH IPRO RING SHIPS WITH AEGIS™ COLLOIDAL SILVER SHAFT COATING PN CS015



Improving the conductivity of the steel shaft surface enhances the shaft voltage discharge capability in AEGIS™ iPRO shaft grounding applications. Maintaining a highly conductive shaft surface is especially important in critical applications or in applications where the conductive shaft surface of steel could become compromised. Apply to any VFD driven motor shaft prior to installing AEGIS™ iPRO.

Applications:

- Medium Voltage Motors
- Large AC Motors
- Power Station Generators
- Gas Turbine Generators
- Emergency Generators
- Gear Boxes

AEGIS™ iPRO

- High frequency shaft currents up to 100 MHz
- Compatible with monitoring equipment
- Long term reliable performance
- Available for shaft diameters from 3" to 30" (76mm to 762mm)

Split Ring Dimensions for maximum shaft diameter up to 12" (304mm)*

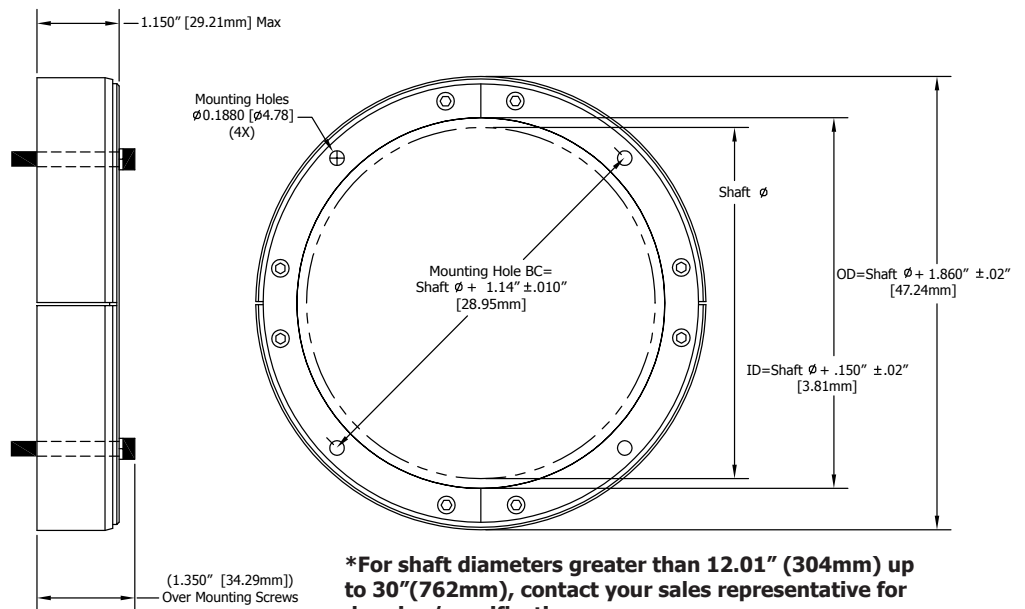

***For shaft diameters greater than 12.01" (304mm) up to 30"(762mm), contact your sales representative for drawing/specifications.**

Note:

1. Shaft must be clean & free of any coatings, paint, or other nonconductive material. Apply CS015 shaft coating to enhance shaft conductivity
2. iPRO is installed over the shaft and secured to the end bell. Microfibers contact shaft 360°
3. On the opposite end of the iPRO installation, the bearing journal should be insulated or insulated/ceramic bearing installed to disrupt circulating currents

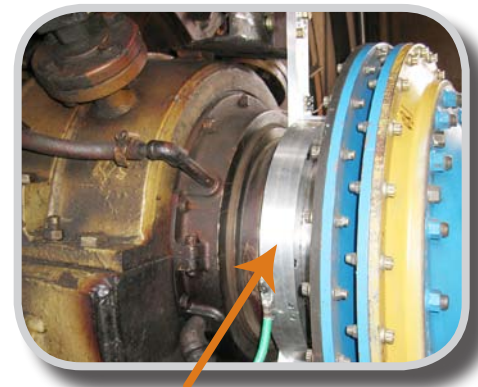

iPRO installed at a power station

Authorized Distributor



Tel: 1-866-738-1857
Fax: 1-207-998-5143
sales@est-aegis.com
www.est-aegis.com