



PRODUCT COM #564
April 27, 2009

TO: Field Sales, Wausau Motor Marketing, Motor Representatives, Application Engineering, Warranty Service,
HVAC/R Sales Team

FROM: Chris Voll

SUBJECT: Field Installable Shaft Ground Ring Kits

Beware Bearing Currents....Marathon Electric Announces "SGR"

Tired of premature bearing failures?...me too! It gives me great pleasure to introduce the Shaft Ground Ring or SGR, the latest innovative product addition to our extensive line of field installable kits. Given the fact that we are the leaders in Variable Frequency Drive (VFD) motors with the MAX motor family, it should be no surprise that we have raised the bar again with this new solution to a very real problem with VFDs. We have spent hundreds of hours testing and understanding the interaction between the VFD and the AC induction motor, we discovered that the problem exists with all VFDs and all the motors they control. While VFDs deliver impressive energy savings (up to 30% or more), they also introduce harmful common mode voltages (CMV) onto the shaft of those motors. The resulting currents will damage motor bearings, which result in costly downtime and premature motor failure. Any truly "green" process must achieve sustainability as well as energy efficiency. The SGR kits make this possible by dramatically extending the lives of motors controlled by VFDs.

The SGR can be included to a build-up Marathon Electric motor during assembly or added through Mod Central. These kits are designed to be a retro fit for all Marathon Electric NEMA T or TS shaft, non flanged motors. They are easily installed, usually within minutes. Unlike conventional grounding brushes, the SGR is maintenance-free and works with virtually no friction or wear for the service life of the motor. The SGR kit incorporates a shaft ground ring, an adhesive ring, two screws, grounding pig tail and mounting instructions. Included with this letter is a PowerPoint presentation, installation instruction sheet and a catalog page. The PowerPoint is very helpful to understand the problem and solution. Typical uses are any VFD controlled motor with a NEMA T or TS shaft and standard drive end bracket.

Feel free to call me with additional SGR or stub shaft kit potential capabilities or additional modifications.

Attachments

Solving VFD-sourced Bearing Current Problems in AC Motors.



The 2 main sources of motor shaft voltage are:

1. Asymmetric Motor construction
 - The stator and rotor magnetic circuits within the motor itself are unbalanced (current path stays within the motor)
2. Unbalanced supply voltage (current path is between the motor and VFD)
 - Unbalance is between the motor and power source
 - **Operation from a VFD creates an unbalanced supply condition.**
 - **The 3 phase output waveform is produced by switching DC voltage On & OFF**
 - **Common Mode Voltage (CMV) results from the voltage wave forms from each of the three phases not summing to zero**



Common Mode Voltage (CMV):

Unbalanced line voltage

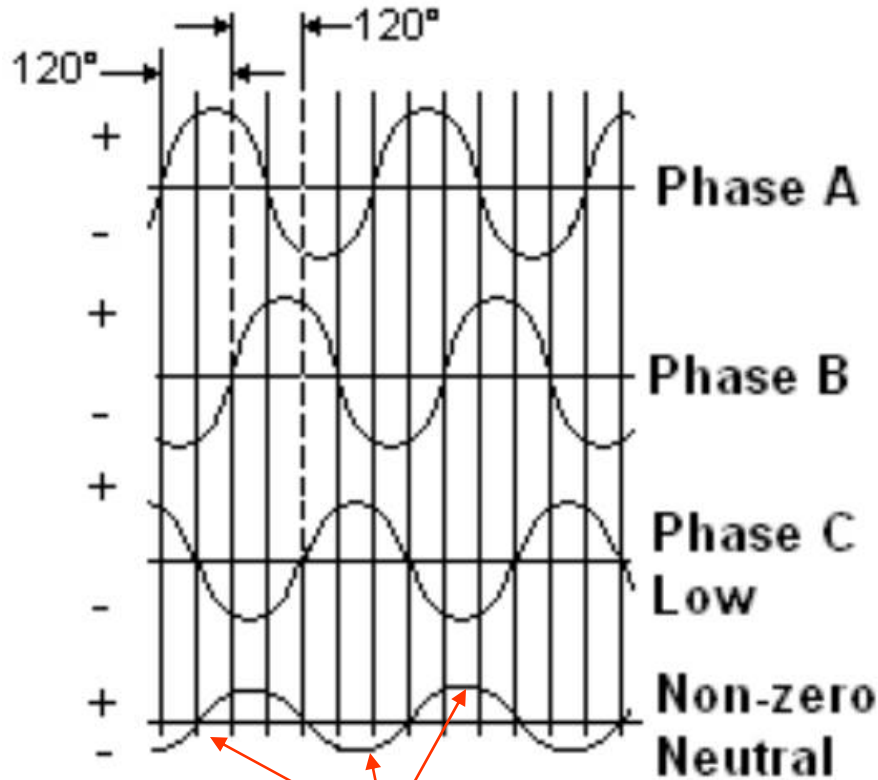

Voltages should sum to zero but don't if the 3 phases are unbalanced. Neutral might reach 20-30 volts with severe unbalance.

VFD voltage is inherently unbalanced

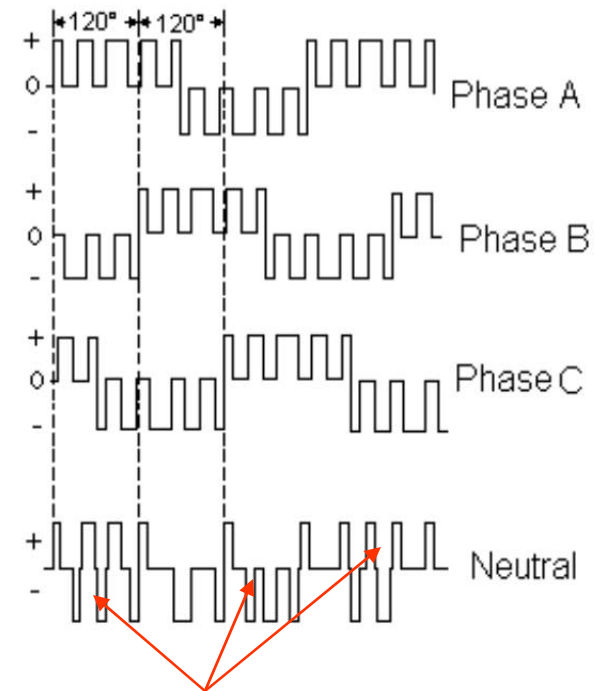

Problem is worse on 460 V VFD power. Motor neutral reaches 375 V!

CMV is an electrostatic voltage. A small portion is coupled from the stator windings to the rotor.

- A static charge builds up over the entire rotor surface
 - Just like shuffling your feet across the carpet on a dry winter day.
 - Charge builds up over your whole body
 - Discharge occurs when you touch a grounded object
- The rotor charge discharges to ground through the bearings and returns to the VFD

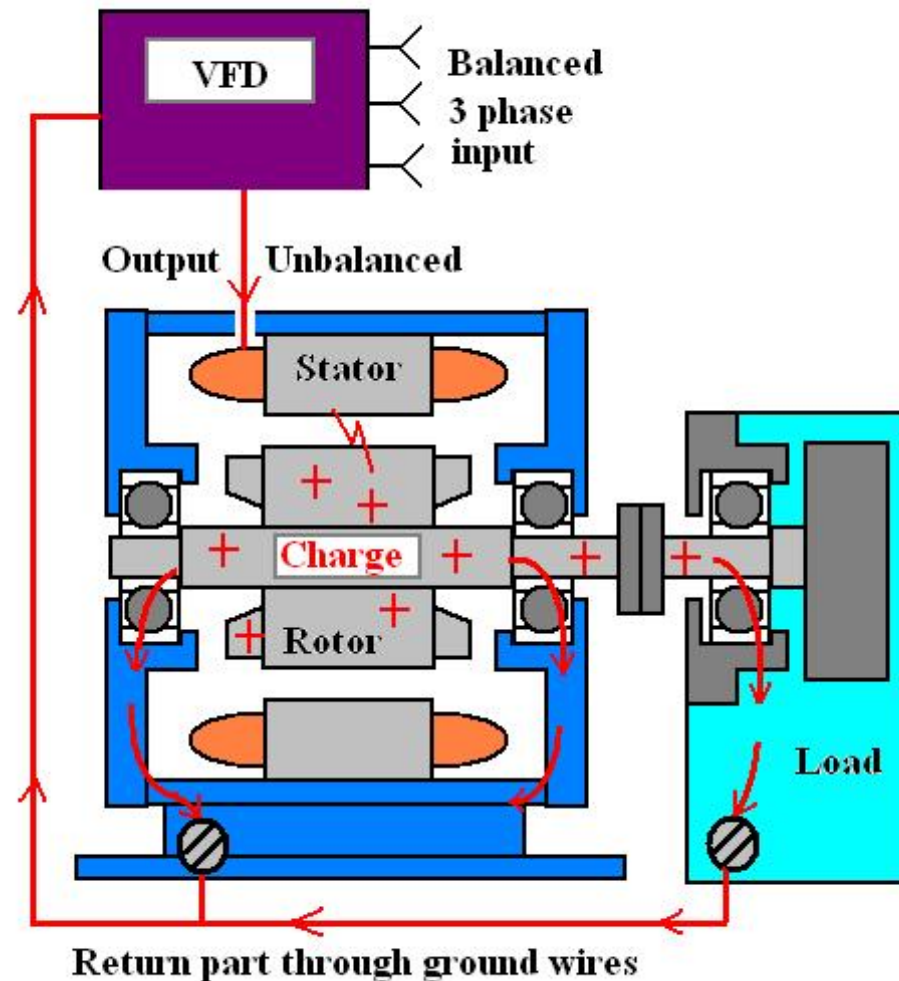

What effect does this have on the bearings?

- Rotor charge builds up until it exceeds the insulation level of the bearing's oil film
- The stored energy produces an arc as the rotor voltage collapses
 - It arcs from the inner race through the rolling elements to the outer race, then to ground
- Current flow is concentrated in a pinpoint-sized area where the ball meets the races
- Such high energy concentration melts the bearing metal, creating microscopic pits

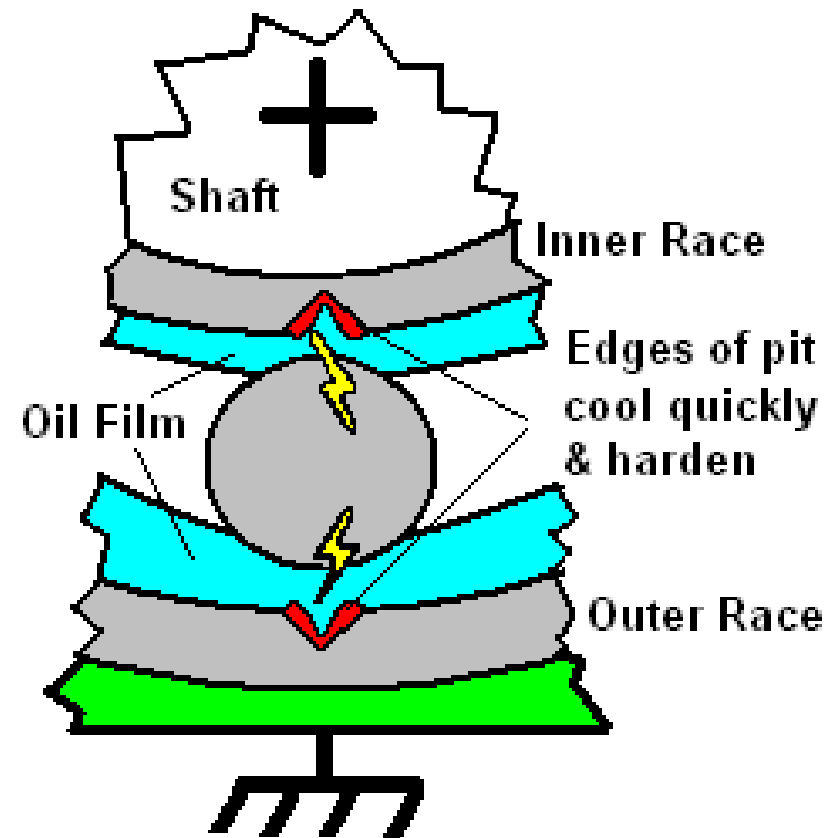

Repeated discharges can be seen on the raceways:

- Both races and rolling elements are affected
- Inner race & rolling elements will become “frosted”
- Vibrations + arcing = Fluting
- Flutes form on outer race
- Noise, temperature & vibration increase dramatically

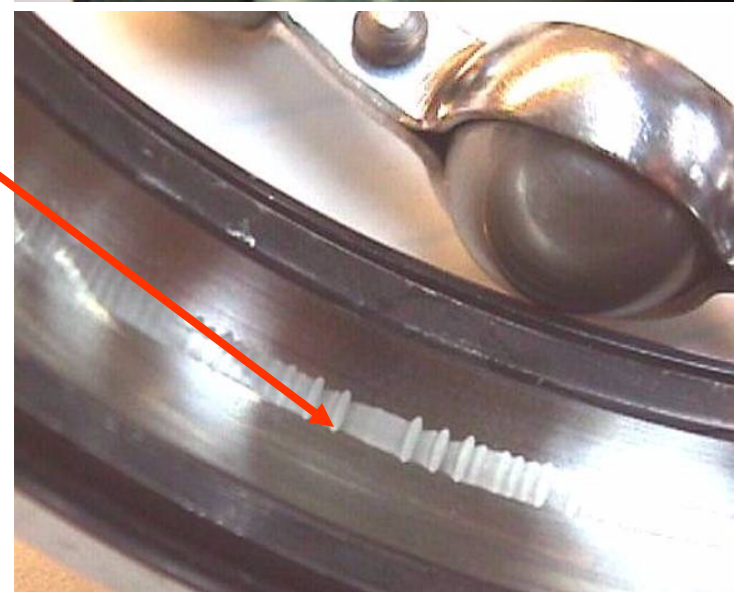
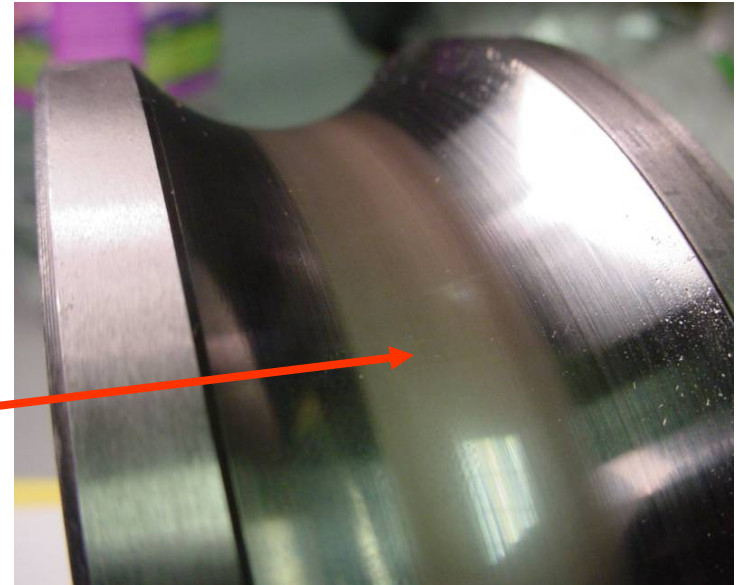

Roller bearings are affected too!



Which motors are susceptible?

ALL OF THEM

All motors powered by VFDs, which by design produce CMV

All manufacturers/brands of AC Induction motors

All motor frame size

All horsepower ratings

All speeds

All bearing types

All duty cycles

All applications

- * Variable Torque
- * Constant Torque
- * Constant Horsepower

.....**All the time**



To eliminate VFD-sourced bearing currents:

1. Reduce or cancel CMV before it reaches the rotor:

- Install CM loading filter (with RC network to ground) at the VFD output
- Add Marathon's patented Faraday shield in the stator windings

---OR---

2. Protect the motor bearings by one or a combination of devices:

- Ground brush (bleeds off charge)
- Insulated bearings (insulation blocks current)
- **Shaft Grounding Ring (bleeds off charge)**



Do Ground Brushes really work?

- Yes! One brush will reduce shaft voltage by ~99%
.....BUT...
- They wear out, requiring regular maintenanceAND...
- External brushes are not permitted in Div 1/Zone 1 or Div 2/Zone 2 Hazardous locations

What about insulated bearings?

- Yes! Insulated bearings are effective.....BUT...
- They can be up to 10 times the cost.....AND...
- Extended lead-time
- Insulated bearings aren't permitted in Hazardous locations either



What is AEGIS Bearing Protection Ring Technology?

- AEGIS SGR is a circumferential ring of conductive micro fibers that reduce the shaft voltage to a safe level
- AEGIS Shaft Grounding Ring provides a reliable discharge path for shaft voltagesAND...
- Because there is no wear pressure on the fibers AEGIS SGR is the most reliable and longest lasting solution to bearing currents
- AEGIS Protects both the motor and attached equipment



Comparison of Techniques.

	AEGIS SGR™	Insulating sleeve	Ceramic/ Hybrid Bearing	Copper or Bronze Metal Brush	Carbon Block Brush	Conductive Grease
Protects Motor and Attached Equipment	Yes	No	No	No	No	No
Long-term Effectiveness	Yes	No	No	No	No	No
Easy to install	Yes	No	No	No	No	No
Contamination Proof	Yes	N/A	N/A	No	No	N/A
Low Lifetime Cost High return on Investment	Yes	No	No	No	No	No
Effective at any RPM	Yes	Yes	Yes	No	No	No
Maintenance Free Operation	Yes	Yes	Yes	No	No	No



Field add-on kits will be in stock soon!

- Fits 90% of all Marathon Electric footed motors
 - Mounts on drive end bracket or on encoders
 - Takes up only 3/8" of shaft
 - No machining required
 - Fits TEFC & encoders too
 - No Div 1 or 2
- Expect inventory during Q109



Kit components and instructions:

INSTALLATION INSTRUCTIONS:

1. CLEAN MOTOR BRACKET AND MOTOR SIDE OF SGR TO REMOVE GREASE AND DIRT.
2. PEEL ONE LINER FROM ADHESIVE DISK AND ATTACH DISK TO MOTOR SIDE OF SGR. IF KIT HAS TWO DISKS, PEEL REMAINING LINER. PEEL ONE LINER FROM SECOND DISK AND ATTACH THIS TO THE FIRST DISK, WITH GLUE SIDE TO GLUE SIDE.
3. PEEL LAST LINER FROM DISK AND SLIDE SGR UP SHAFT OF MOTOR. PRESS INTO POSITION ON MOTOR BRACKET.
4. ATTACH PIGTAIL TO SGR WITH THE SCREW PROVIDED (2ND HOLE ON SGR IS NOT USED).
5. DRILL 1/8" DIAMETER HOLE 1/4 TO 5/16" DEEP INTO GREASE DRAIN CHANNEL OR RIB OF BRACKET. CAN USE SHORTER OR LONGER PIGTAIL AND ATTACH TO MOTOR FOOT IF DESIRED.
6. REPLACE SHAFT SLINGER WHEN FINISHED. MAKE SURE SLINGER DOES NOT RUB AGAINST SGR.

CLEAN FRONT OF BRACKET FACE WITH ISOPROPYL ALCOHOL OR LACQUER THINNER

MOTOR SIDE OF SGR IS CURVED

ADHESIVE DISK (KIT MAY HAVE TWO)

SGR RING

8-32 SCREWS

REPLACE SLINGER AFTER INSTALLATION

REMOVE LINERS FROM DISKS BEFORE ASSEMBLY

PIGTAIL LEAD

WARNING:
NOT FOR USE IN HAZARDOUS LOCATIONS AS DEFINED IN NFPA 70 (NEC ARTICLE 500)

		TOLERANCES UNLESS SPECIFIED:		REGAL-BELT CORPORATION	DRAWN RWR 08-01-2008	
		DEC	INCHES		CHK ML 08-07-2008	
		X	±.1		APPR JM 08-08-2008	
		.XX	±.02		SCALE 1:5	
		.XXX	±.005		REF	
		.XXXX	±.0005	MATL	FMF MARKETING	
NO	REVISION	BY & DATE	CHK ANG ±7.30°	FINISH	PAGE OF	
THIRD ANGLE PROJECTION		RFP 08-11-2008	PREV	SIZE A	DRAWING NO FORM_219	REV
			NETWORK FILE NAME FORM_219			



Bearing failures are costly...take care of them...you don't want to deal with this...



For more information, request power point file *Brgcurrent25*.



Shaft Grounding

Shaft grounding is recommended (NEMA MG1 31.4.4.3) as an effective means of bearing protection for motors operated from inverter power. One grounding device is adequate to bleed down inverter-sourced shaft voltages, thereby protecting both bearings for motors as large as 6085 frame. Kits includes grounding ring, mounting hardware and instructions. Shaft ground rings fit these NEMA shaft extension frames listed below, they are designed to mount on the shaft end.

SHAFT GROUNDING RING (SGR)

Frame	Kit No.	Cat No.	STOCK	Build-Up	Kits	MOD Central (installed)
48	KIT SGR-11.2	A500-5	*	\$92	\$195	\$395
56	KIT SGR-14.4	A500-8	*	\$92	\$195	\$395
143-145T	KIT SGR-20.7	A500-14	*	\$92	\$207	\$441
182-184T	KIT SGR-27.1	A500-20	*	\$116	\$225	\$456
213-215T	KIT SGR-33.4	A500-26	*	\$140	\$254	\$472
254-256T	KIT SGR-39.8	A500-32	*	\$187	\$313	\$681
284-286T	KIT SGR-46.1	A500-38	*	\$234	\$374	\$711
284-286TS	KIT SGR-39.8	A500-32	*	\$234	\$313	\$711
324-326	KIT SGR-52.5	A500-44	*	\$282	\$433	\$788
324-326TS	KIT SGR-46.1	A500-38	*	\$282	\$374	\$788
364-365	KIT SGR-58.8	A500-50	*	\$329	\$492	\$950
364-365TS	KIT SGR-46.1	A500-38	*	\$329	\$374	\$950
404-405	KIT SGR-71.5	A500-62	*	\$519	\$728	\$1,038
404-405TS	KIT SGR-52.5	A500-44	*	\$519	\$433	\$1,038
444-445T	KIT SGR-84.2	A500-74	*	\$898	\$1,043	\$1,327
444-445TS	KIT SGR-58.8	A500-50	*	\$898	\$492	\$1,327
447/449T	KIT SGR-84.2	A500-74	*	\$898	\$1,043	\$1,327
447/449TS	KIT SGR-58.8	A500-50	*	\$898	\$492	\$1,327
5000S	KIT SGR-65.2	A500-56		\$1,300	\$728	N/A
5000LS	KIT SGR-71.5	A500-62		\$1,300	\$728	N/A
5000LX	KIT SGR-96.9	A500-86		\$1,300	\$1,675	N/A
5000L	KIT SGR-100.1	A500-89		\$1,300	\$1,675	N/A
6805	KIT SGR-126.5	A500-114		\$1,419	\$2,132	N/A



Grounding devices may not be installed on motors used in Division I or Division 2 hazardous locations.

INSTALLATION INSTRUCTIONS:

1. CLEAN MOTOR BRACKET AND MOTOR SIDE OF SGR TO REMOVE GREASE AND DIRT.
2. PEEL ONE LINER FROM ADHESIVE DISK AND ATTACH DISK TO MOTOR SIDE OF SGR. IF KIT HAS TWO DISKS, PEEL REMAINING LINER. PEEL ONE LINER FROM SECOND DISK AND ATTACH THIS TO THE FIRST DISK, WITH GLUE SIDE TO GLUE SIDE.
3. PEEL LAST LINER FROM DISK AND SLIDE SGR UP SHAFT OF MOTOR. PRESS INTO POSITION ON MOTOR BRACKET.
4. ATTACH PIGTAIL TO SGR WITH THE SCREW PROVIDED (2ND HOLE ON SGR IS NOT USED).
5. DRILL 1/8" DIAMETER HOLE 1/4 TO 5/16" DEEP INTO GREASE DRAIN CHANNEL OR RIB OF BRACKET. CAN USE SHORTER OR LONGER PIGTAIL AND ATTACH TO MOTOR FOOT IF DESIRED.
6. REPLACE SHAFT SLINGER WHEN FINISHED. MAKE SURE SLINGER DOES NOT RUB AGAINST SGR.

CLEAN FRONT OF BRACKET FACE WITH ISOPROPYL ALCOHOL OR LACQUER THINNER

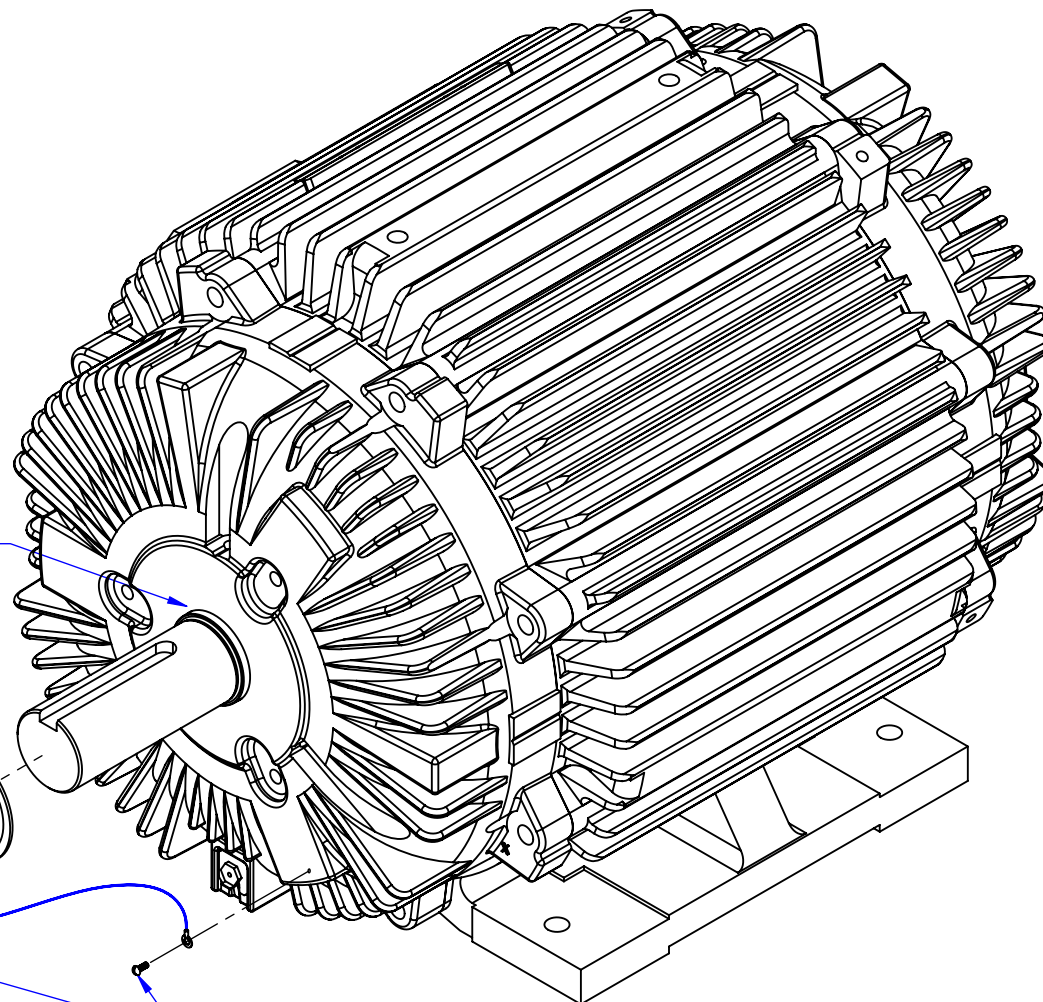

MOTOR SIDE OF SGR IS CURVED

ADHESIVE DISK (KIT MAY HAVE TWO)

SGR RING

8-32 SCREWS

REPLACE SLINGER AFTER INSTALLATION

REMOVE LINERS FROM DISKS BEFORE ASSEMBLY

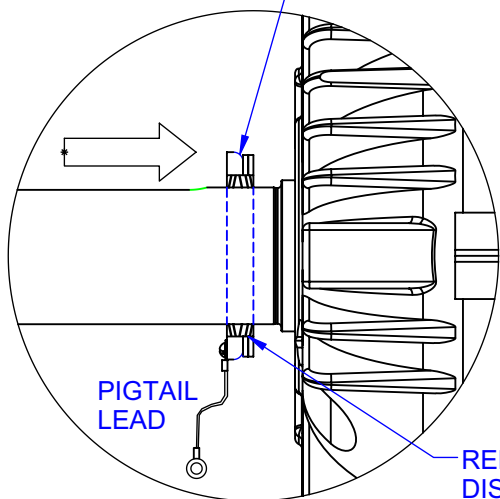

PIGTAIL LEAD

WARNING:
NOT FOR USE IN HAZARDOUS LOCATIONS AS DEFINED IN NFPA 70 (NEC ARTICLE 500)

				TOLERANCES UNLESS SPECIFIED		 REGAL-BELOIT CORPORATION		DRAWN RWR 08-01-2008		
				DEC	INCHES			CHK ML 08-07-2008		
				.X	±.1	TITLE SHAFT GROUNDING RING KIT		APPR JM 08-08-2008		
				.XX	±.02	SCALE 1:5		REF		
				.XXX	±.005	MAT'L		FMF MARKETING		
				.XXXX	±.0005	FINISH		PAGE OF		
NO	REVISION	BY & DATE	CHK	ANG	±7'30"	PREV		SIZE A	DRAWING NO FORM_219	REV
				RFP	08-11-2008	NETWORK FILE NAME FORM_219				

THIRD ANGLE PROJECTION

